

## 工艺参数 Technological parameters

产品系列 Product series	A D - M 6
纱线支数 Count range of yarn	Ne 6-200
喂入直径 Feed diameter of package	φ250mm
纱线品种 Type of yarn	短纤、长丝 Staple fiber、Filament yarn
卷取速度 Winding speed	1200m/min (依据生产工艺 Depending on process parameters)
成卷直径 Diameter of assembled package	φ220mm
成卷重量 Diameter of assembled package	4kg
适配筒管 Type of yarn bobbin	6" - 8" (根据客户要求 Depending on customer request)
一般应用 Common application	并纱、松筒、倒筒 (Assembly winding、Soft winding、Rewinding)

## 外形尺寸 Layout

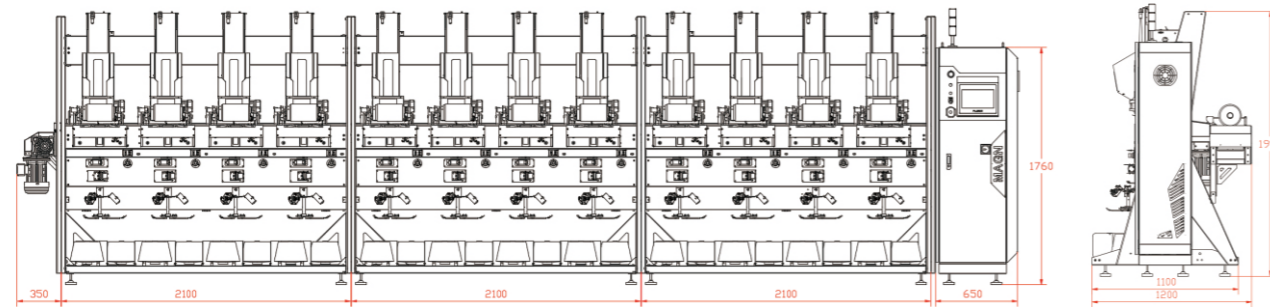

## 机器尺寸 Machine dimensions

锭数 Quantity	4锭/Sp	8锭/Sp	12锭/Sp	16锭/Sp	20锭/Sp	24锭/Sp	28锭/Sp	32锭/Sp	36锭/Sp	40锭/Sp	44锭/Sp	48锭/Sp	52锭/Sp	56锭/Sp	60锭/Sp
长度 Length(mm)	3100	5200	7300	9400	11500	13600	15700	17800	19900	22000	24100	26200	28300	30400	32500
宽度 Width(mm)	1200														
高度 Heigh(mm)	2020														
净重 Net weight(kg)	680	1240	1800	2360	2920	3480	4040	4600	5160	5720	6280	6840	7400	7960	8520

## Assembly Winder of Auto Doffing 自动换管并纱机

# MAGN

苏州英迈杰机械有限公司  
Suzhou Imagin Machinery Co.,Ltd.

地址: 江苏省苏州工业园区唯文路7号  
Block A, No.7 Weiven Road, Suzhou Industrial Park, Suzhou, Jiangsu, China

电话: 0086-512-6706 6492  
传真: 0086-512-6706 6493  
网址: www.imaginsz.com

江苏省南通海安市和顺路88号  
No.88 Heshun Road, Hai'an Nantong Jiangsu, China

Tel: 0086-512-6706 6492  
Fax: 0086-512-6706 6493  
Http: www.imaginsz.com

- 本样本仅作参考，不作为技术验收依据。
- 为提高产品质量，本公司保留更改规格之权力，恕不另行通知。
- We reserve the right to modify the characteristics of the machines described herein without prior notice.
- The data given in this brochure are not intended as a guarantee.

苏州英迈杰机械有限公司  
Suzhou Imagin Machinery Co.,Ltd.

## 特点 Features

- 快速卷绕, 速度可达1200m/min;  
Fast winding, speed up to 1200m/min.
- 精准的米长控制, 偏差更小;  
Higher precision for length control, and the less deviation.
- 换管精准度高, 效率提升10%以上;  
Higher precision of doffing, efficiency increase by more than 10%.
- 纱库升级设计, 续航能力增加20%;  
Upgrade design of yarn storehouse, battery life increase by 20%.
- 横动拨叉配置, 卷绕成型更完美;  
Transverse fork configuration, more perfect winding forming.

## 选择 AD-M6系列自动换管机, 您能实现

What can you expect from automatic doffer of AD-M6 series

- 卷绕过程自动化, 生产用工节省30%;  
Full automation of winding, Production labor saving of 30%.
- 数字背压控制, 纱卷内外密度更均匀;  
Digital force control, more uniform density inside and outside of yarn package.
- 高质量的卷绕工艺过程, 落纱成型更好;  
Higher quality winding process, yarn forming is better.
- 专业的卷绕解决方案, 根据客户要求定制;  
Professional winding solution, customized according to customer requirements.

## 主要参数 Features

型号	Type	FW\FS\FD-M6
锭距	Gauge	505mm
每节锭数	Spindles per section	4锭
锭数配置	Spindles configuration	60锭(单面) Single side
卷绕速度	Winding speed	1200m/min
卷绕驱动	Winding drive	单锭伺服电机 Individual servo motor
动程范围	Traverse range	50~230mm
换管形式	Doffing type	全自动(气动) Automatic(pneumatic)
张力控制	Yarn tension	开环或闭环 Open-loop or close-loop
背压控制	Force control	数字背压 Digital force
选配装置	Optional device	远程监控系统 Remote monitoring system
		落纱自动输送系统 Automatic conveying system

